

KNIFE - GATE VALVES

A SERIES

ΒΑΝΕΣ ΜΑΧΑΙΡΩΤΕΣ

30/10/2013

UNIDIRECTIONAL WAFER Knife Gate Valve

- Unidirectional wafer-design knife gate valve.
- One-piece cast body with guides to support gate and seat wedges.
- Provides high flow rates with low pressure drop.
- Various seat and packing materials available.
- Face-to-face dimension in accordance with CMO standard.
- An arrow is marked on the body indicating the flow direction.

General Applications:

- This knife gate valve is suitable for liquids that contain a maximum of 5% suspended solids. If it is used for dry solids in gravity feed applications it should be installed with the arrow on the body pointing in the opposite direction to the flow. Designed for applications such as:
 - Paper Industry
 - Mining
 - Silo emptying
 - Chemical plants
 - Pumping
 - Food Industry
 - Sewage treatment

Sizes: ND50 to ND2000 (larger sizes on request).

Working Pressure: -ND50 to ND150: 10kg/cm² -ND200: 8kg/cm²
 -ND250 to ND300: 6kg/cm² -ND350 to ND400: 5kg/cm²
 -ND450 to ND600: 3kg/cm² -ND700 to ND1400: 2kg/cm²

-These pressures must be applied to the valve in the direction of the arrow marked on the valve's body. Due to the valve's design with gate support guides, 30% of these pressures can be applied in the opposite direction to the arrow.

Standard Flanges: DIN PN10 and ANSI B16.5 (class 150)

Other Common Flanges: DIN PN 6 DIN PN 16 DIN PN25
 BS "D" and "E" ANSI 150 Others on request:

Directives: Machinery Directive: **DIR 2006/42/EC (MACHINERY)**
 Pressure Equipment Directive: **DIR 97/23/EC (PED) ART.3, P.3**
 Potential Explosive Atmospheres Directive: **DIR 94/9/EC (ATEX) CAT.3 ZONE 2 and 22 GD**
 For further information on categories and zones please contact the CMO Technical-Commercial Dept.

Quality Dossier:

- All valves are tested hydrostatically at CMO and material and test certificates can be provided.
- Body test = working pressure x 1.5.
- Seat test = working pressure x 1.1.

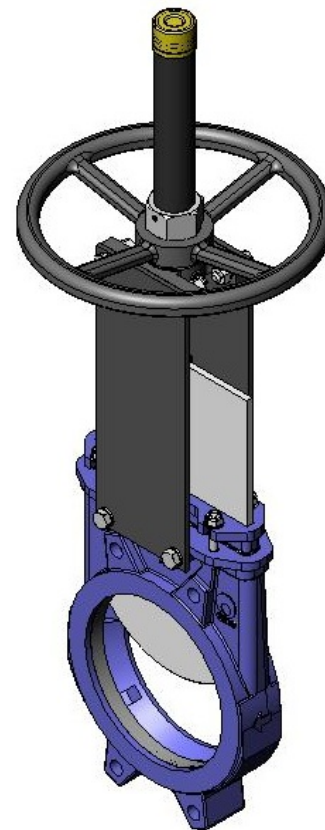

Fig. 1

C.M.O.

KNIFE-GATE VALVES

A SERIES

Advantages of CMO's "Model A" compared to similar products

When a knife gate valve remains open for long periods of time and the body's internal walls are parallel a very large torque is required to close it. Model A's body is cone-shaped inside, providing greater space. This way, when the valve is closed the solids stored inside it can be easily removed.

This valve is defined as unidirectional and these valves are normally at risk of the gate bending due to counter-pressure. This cannot happen with the CMO valve because it contains internal guides that support the knife gate and allow it to work under counter-pressure of 30% of the maximum working pressure, without the knife gate bending.

The stem protection hood is independent from the handwheel securing nut, this means the hood can be disassembled without the need to release the handwheel. This advantage allows regular maintenance operations to be performed, such as lubricating the stem, etc.

The stem on the CMO valve is made of 18/8 stainless steel. This is another added advantage, as some manufacturers produce it with 13% chrome and it gets rusty very quickly.

The handwheel is made of GJS-500 nodular cast iron. Some manufacturers produce them in normal cast iron which can lead to breakages in the event of very high operating torque or knocks.

The yoke is has a compact design with the bronze actuator nut protected in a sealed and lubricated box. This makes it possible to move the valve with a key, even without the handwheel (in other manufacturers' products this is not possible).

The pneumatic actuator's upper and lower covers are made of GJS-400 nodular cast iron, making them highly shock resistant. This characteristic is essential in pneumatic actuators.

The pneumatic cylinder's o-ring seals are commercial products and can be purchased worldwide. This means it is not necessary to contact CMO every time a seal is required.

STANDARD COMPONENTS LIST		
COMPONENT	CAST IRON VERSION	ST. STEEL VERSION
1- Body	GJL-250	CF8M
2- Gate	AISI304	AISI316
3- Guide	RCH1000	RCH1000
4- Packing gland	GJS-500	CF8M
5- Packing	SYNT + PTFE	SYNT + PTFE
6- O-ring seal	EPDM	EPDM
7- Support plates	S275JR	S275JR
8- Ring	AISI316	AISI316
9- Seat	EPDM	EPDM
10- Stem	AISI303	AISI303
11- Yoke	STEEL	STEEL
12- Stem nut	BRONZE	BRONZE
13- Check nut	ST44.2 + ZINC	ST44.2 + ZINC
14- Handwheel	NODULAR CAST IRON	NODULAR CAST IRON
15- Nut	STEEL	STEEL
16- Hood	STEEL	STEEL
17- Top cap	PLASTIC	PLASTIC

table 1

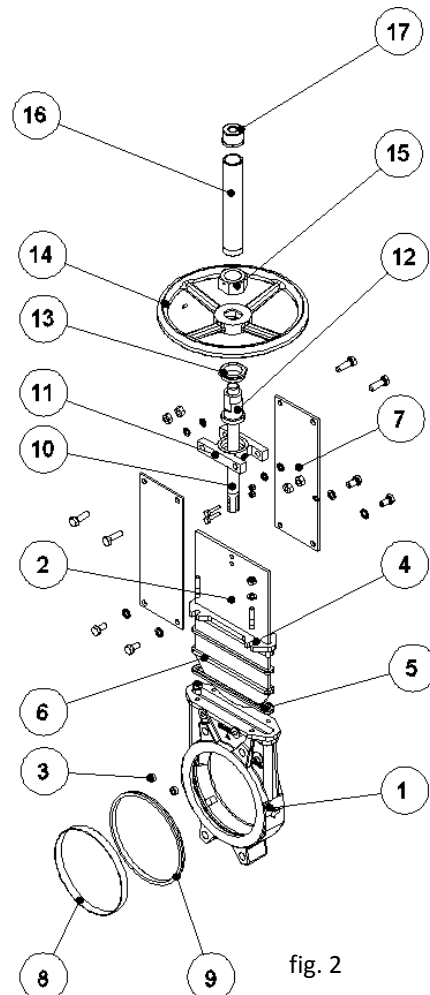

fig. 2

C.M.O.

KNIFE-GATE VALVES

A SERIES

DESIGN CHARACTERISTICS

1- BODY

Unidirectional wafer-design knife gate valve. One-piece cast body with guides to support gate and seat wedges.

For diameters greater than ND1200 the body is machine-welded with the necessary reinforcements to resist the maximum working pressure.

Full port designed to provide high flow rates with low pressure drop.

The body's internal design prevents any build up of solids in the seat area.

The standard manufacturing materials are GJL-250 cast iron and CF8M stainless steel. Other materials, such as GJS-500 nodular cast iron, A216WCB carbon steel and stainless steel alloys (AISI316Ti, Duplex, 254SMO, Uranus B6...) are available on request. As standard, iron or carbon steel valves are painted with an anti-corrosive protection of 80 microns of EPOXY (colour RAL 5015). Other types of anti-corrosive protections are available on request.

2- GATE

The standard manufacturing materials are AISI304 stainless steel in valves with iron body and AISI316 stainless steel in valves with CF8M body. Other materials or combinations can be supplied on request.

The gate is polished on both sides to provide a smooth contact surface with the resilient seat. At the same time, the gate is rounded to prevent the seat from being cut. Different degrees of polishing, anti-abrasion treatments and modifications are available to adapt the valves to the customer's requirements.

3- SEAT: (watertight)

Six types of seats are available according to the working application:

Seat 1: Metal / metal seat. This type of seat does not include any kind of resilient seat and the estimated leakage (considering water as the test fluid) is 1.5% of the pipe flow.

Seat 2: Standard soft-seated valve. This type of seat includes a resilient seat which is fixed to the inside of the body via an AISI316 stainless steel retaining ring.

Seat 3: Soft-seated valve with reinforced socket. This type of seat includes a resilient seat which is fixed to the inside of the body via an AISI316 stainless steel retaining ring with two functions (to protect the valve from abrasion and clean the gate when working with solids that can stick to it).

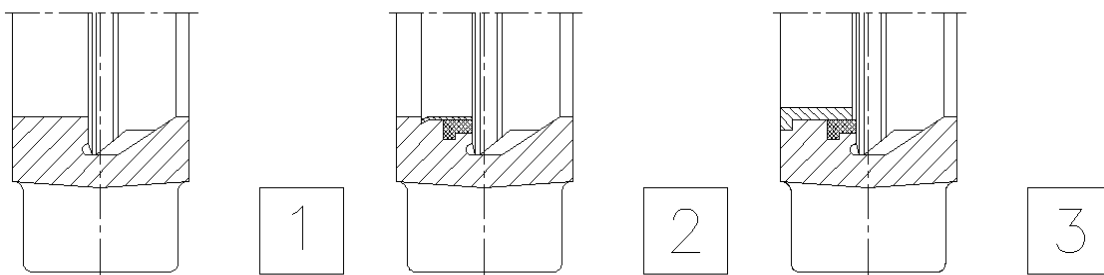

fig. 3

KNIFE-GATE VALVES

A SERIES

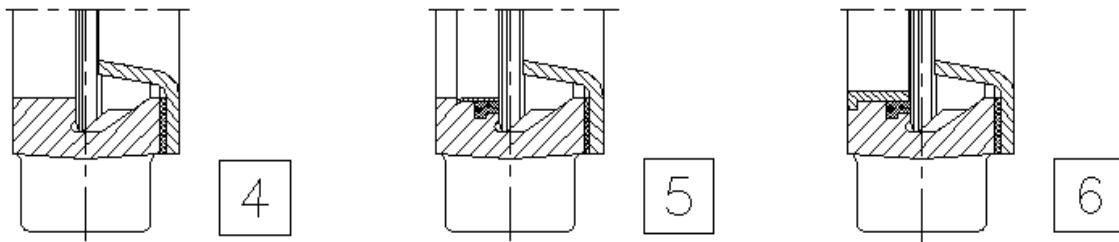



fig. 4

Seats 4, 5 and 6: The same as seats 1, 2 and 3 but including a deflector. The deflector is a cone-shaped ring located at the valve's entrance with two functions (to protect the valve from abrasion and guide the flow to the centre of the valve).

 **Note:** Three materials are available for the reinforced socket and the deflector (CA-15 steel, CF8M and Ni-hard).

Resilient seat materials

EPDM

This is the standard resilient seat fitted on CMO valves. It can be used in many applications, however, it is generally used for water and products diluted in water at temperatures no higher than 90°C*. It can also be used with abrasive products and it provides the valve with 100% watertight integrity.

NITRILE

It is used in fluids containing fats or oils at temperatures no higher than 90°C*. It provides the valve with 100% watertight integrity.

VITON

Suitable for corrosive applications and continuous high temperatures of up to 190°C and peaks of 210°C. It provides the valve with 100% watertight integrity.

SILICONE

Mainly used in the food industry and for pharmaceutical products with temperatures no higher than 200°C. It provides the valve with 100% watertight integrity.

PTFE

Suitable for corrosive applications and pH between 2 and 12. Does not provide the valve with 100% watertight integrity. Estimated leakage: 0.5% of the tube flow.

 **Note:** In some applications other types of resilient materials are used, such as hypalon, butile or natural rubber. Please contact us if you require one of these materials.

4- PACKING

CMO's standard packing is composed of three lines with a specially designed EPDM O-ring in the middle which provides watertight integrity between the body and the gate, preventing any type of leakage to the atmosphere. It is located in an easily accessible place and can be replaced without dismantling the valve from the pipeline. Below we indicate various types of packing available according to the application in which the valve is located:

KNIFE - GATE VALVES

A SERIES

GREASED COTTON (Recommended for hydraulic services): This packing is composed of braided cotton fibres soaked in grease both inside and out. It is for general use in hydraulic applications in both pumps and valves.

DRY COTTON: This packing is composed of cotton fibres. It is for general use in hydraulic applications with solids.

COTTON + PTFE: This packing is composed of braided cotton fibres soaked in PTFE both inside and out. It is for general use in hydraulic applications in both pumps and valves.

SYNTHETIC + PTFE: This packing is composed of braided synthetic fibres soaked in PTFE both inside and out. It is for general use in hydraulic applications in both pumps and valves and in all types of fluids, especially corrosive ones, including concentrated and oxidising oils. It is also used in liquids with solid particles in suspension.

GRAPHITE: This packing is composed of high-purity graphite fibres. A diagonal braiding system is used and it is impregnated with graphite and lubricant which helps to reduce porosity and improve operation. It has a wide range of applications as graphite is resistant to steam, water, oils, solvents, alkali and most acids.

CERAMIC FIBRE: This packing is composed of ceramic material fibres. Its main applications are with air or gas at high temperatures and low pressures.

SEAT/SEALS			PACKING			
Material	Max. T. (°C)	Applications	Material	P(bar)	Max. T. (°C)	pH
Metal/Metal	>250	High temp./Low watertight integ.	Greased cotton	10	100	6-8
EPDM (E)	90 *	Non-mineral acids and oils	Dry cotton	0.5	100	6-8
Nitrile (N)	90 *	Hydrocarbons, oils and greases	Cotton + PTFE	30	120	6-8
Viton (N)	200	Hydrocarbons and solvents	Synthetic + PTFE	100	-200+270	0-14
Silicone (S)	200	Food Products	Graphite	40	650	0-14
PTFE (T)	250	Corrosion resistant	Ceramic Fibre	0.3	1400	0-14

NOTE: More details and other materials available on request.

* → EPDM and nitrile: is possible until serving temperature Max.: 120°C under request.

table 2

5- STEM

The stem on the CMO valve is made of 18/8 stainless steel. This characteristic provides high resistance and excellent corrosion-resistant properties.

The valve design can be rising stem or non-rising stem. When rising stem is required a stem hood is supplied to protect the stem from contact with dust and dirt, as well as keeping it lubricated.

6- PACKING GLAND

The packing gland allows uniform force and pressure to be applied to the packing to ensure watertight integrity.

As standard, valves with cast iron body include GJS-500 packing glands, whilst valves with stainless steel body have CF8M packing glands.

KNIFE-GATE VALVES

A SERIES

7- ACTUATORS

All types of actuators can be supplied, with the advantage that the CMO design is fully interchangeable. This design allows the customer to change the actuators themselves and normally no extra assembly accessories are required. In the event any accessory is required, CMO will supply it.

Manual:

- Handwheel with rising stem
- Handwheel with non-rising stem
- Chainwheel
- Lever
- Gear Box
- Others (square nut,...)

Automatic:

- Electric actuator
- Pneumatic cylinder
- Hydraulic cylinder

A design characteristic of CMO S.L. valves is that all actuators are interchangeable.

Wide Range of Accessories Available:

- Mechanical stops
- Locking devices
- Emergency manual actuators
- Solenoid valves
- Positioners
- Limit switches
- Proximity switches
- Floor stands (Fig 5)
- ...

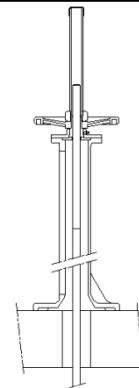
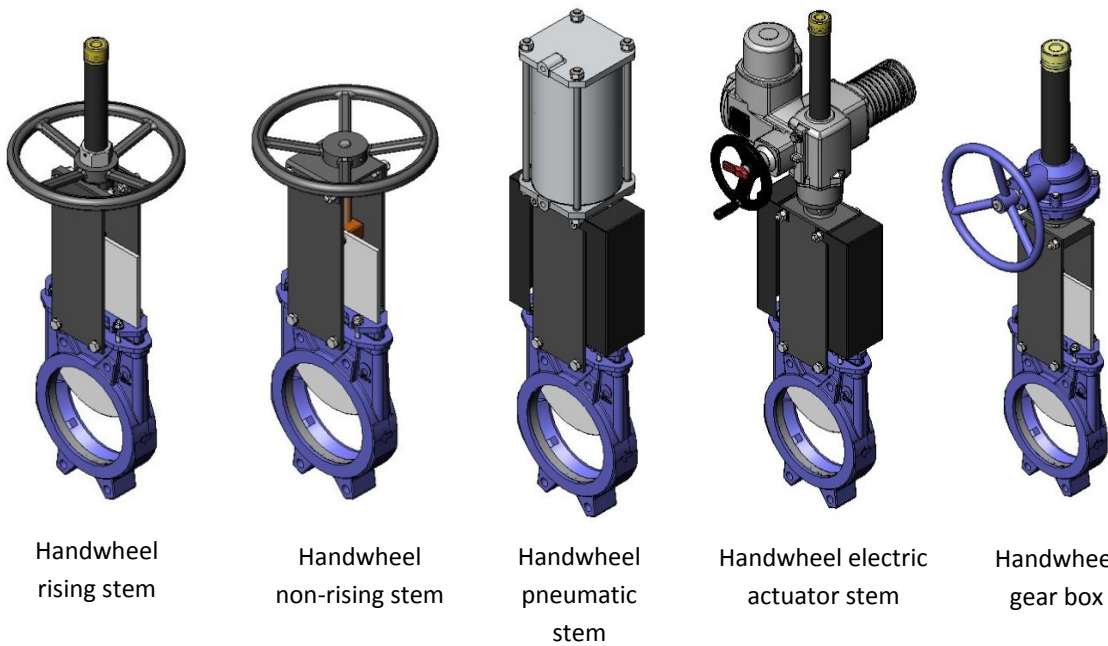

Fig. 5

Stem extensions have also been developed, allowing the actuator to be located far away from the valve, to suit all needs.

Please consult our technicians beforehand.



Handwheel rising stem

Handwheel non-rising stem

Handwheel pneumatic stem

Handwheel electric actuator stem

Handwheel gear box

Fig. 6

C.M.O.

KNIFE - GATE VALVES

A SERIES

ACCESSORIES AND OPTIONS

Different types of accessories are available to adapt the valve to specific working conditions such as:

Mirror Polished Gate

The mirror polished gate is especially recommended in the food industry and, as standard, in applications in which solids can stick to the gate. It is an alternative to ensure the solids slide off and do not stick to the gate.

PTFE Lined Gate

As with the mirror polished gate, it improves the valve's resistance to products that can stick to the gate.

Stellited Gate

Stellite is added to the gate's lower edge to protect it from abrasion.

Scraper in the Packing

Its function is to clean the gate during the opening movement and prevent possible damage to the packing.

Air Injection in the Packing Gland

By injecting air in the packing, an air chamber is created which improves the watertight integrity.

Heating Jacket

Recommended in applications in which the fluid can harden and solidify inside the valve's body. An external jacket keeps the body temperature constant, preventing the fluid from solidifying.

Flushing Holes in Body (Fig. 7)

Several holes can be drilled in the body to flush air, steam or other fluids out in order to clean the valve seat before sealing.

Mechanical Limit Switches, Inductive Switches and Positioners

Limit switches or inductive switches are installed to indicate precise valve position, as well as positioners to indicate continuous position.

Solenoid Valves

For air distribution to pneumatic actuators.

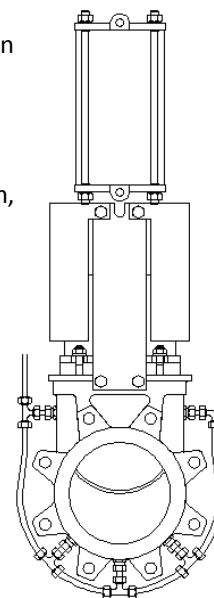

Fig. 7

KNIFE-GATE VALVES

A SERIES

Connection Boxes, Wiring and Pneumatic Piping

Fully assembled units can be supplied with all the necessary accessories.

Stroke Limiting Mechanical Stops

Mechanical Locking Device

Allows the valve to be mechanically locked in a set position for long periods of time.

Emergency Manual Actuator (Hand Wheel /Gear Box)

Allows manual operation of the valve in the event of power or air failure.

Triangular (V-Notch) and Pentagonal Diaphragm with Indication Rule (Fig. 8)

Recommended for applications in which flow regulation is required.

Allows flow control according to the valve's opening percentage.

Interchangeable Actuators

All actuators are easily interchangeable.

Actuator or Yoke Support

Made of EPOXY-coated steel (or stainless steel on request), its robust design gives it great rigidity in order to resist the most adverse operation conditions.

Epoxy Coating

All cast iron and carbon steel bodies and components on CMO valves are EPOXY coated, giving the valves great resistance to corrosion and an excellent finish.

CMO's standard colour is blue, RAL-5015.

Gate Safety Protection

In accordance with European Safety Standards ("EC" marking), CMO automated valves are equipped with gate guards, to prevent any objects from being accidentally caught in the gate.

Bonnet (Fig. 9)

The bonnet provides total watertight integrity to the outside, reducing the packing maintenance required.

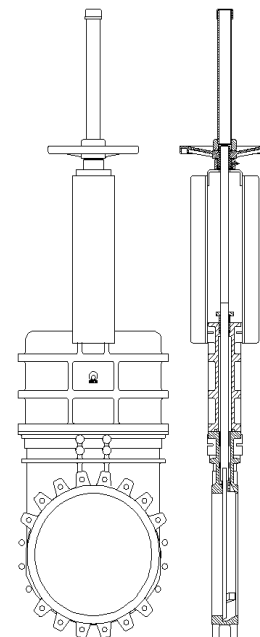
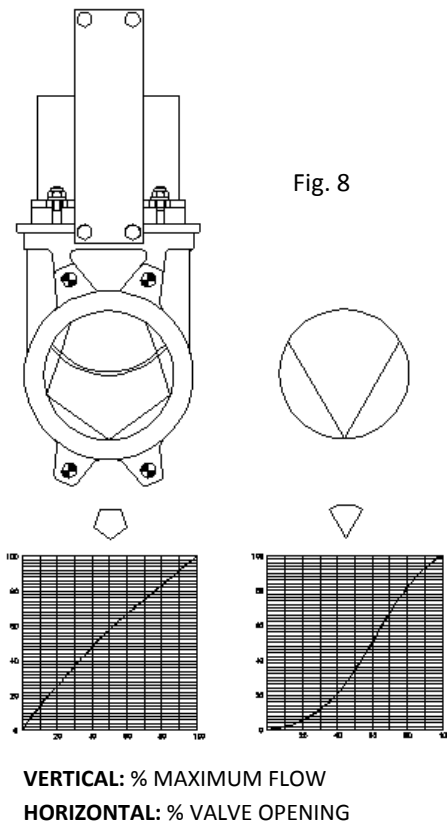

KNIFE-GATE VALVES

A SERIES

TYPES OF EXTENSION

When the valve needs to be operated from a distance, the following different types of actuators can be fitted:

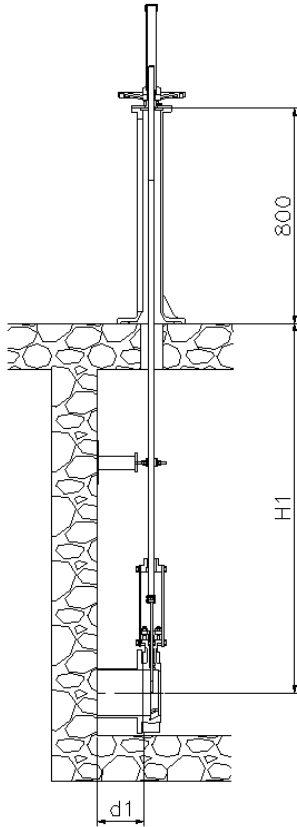

Fig. 10

- Extension: Floor Stand.

This extension is achieved by coupling a rod to the stem. The desired extension length is achieved by defining the length of the rod. A floor stand is normally installed to support the actuator.

The definition variables are as follows:

H1: Distance from the valve's centre to the base of the stand.

d1: Separation from the wall to the end of the connecting flange.

Characteristics:

- It can be coupled to any type of actuator.
- A stem support-guide (Fig. 11) is recommended every 1.5 m.
- The standard floor stand is 800mm high (Fig. 10). Other floor stand measurements available on request:
- A position indicator can be fitted to determine the valve's percentage of opening.
- Tilting stand available on request (Fig. 12).

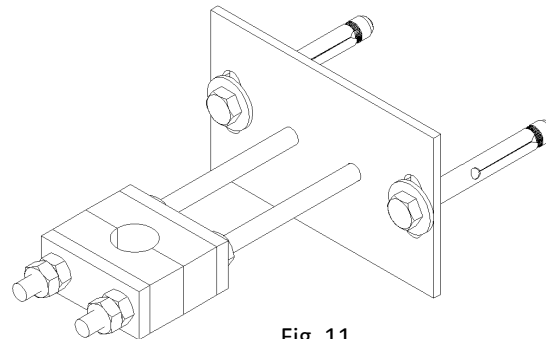

Fig. 11

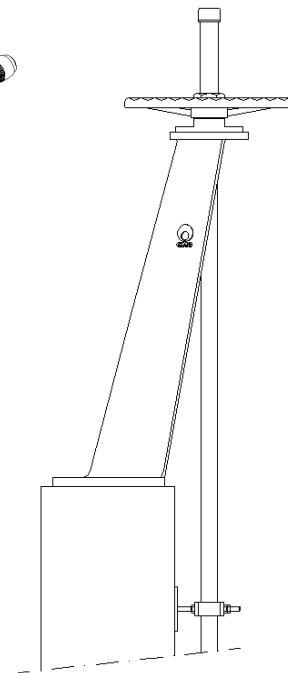

Fig. 12

COMPONENTS LIST	
Component	Standard Version
AISI 304 Stem	AISI 303
Rod	AISI 304
Support-Guide	Carbon steel with EPOXY coating
Guide	Nylon
Stand	GJS-500 with EPOXY coating

Table 3



KNIFE-GATE VALVES

A SERIES

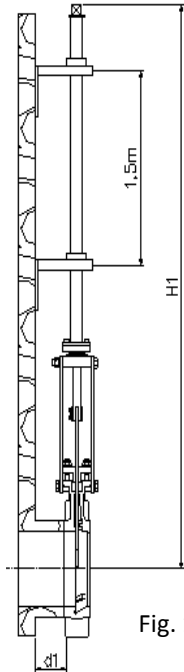

Fig. 13

2 - Extension: Pipe (Fig. 13)

Consists of raising the actuator. The pipe will rotate in the same direction as the handwheel when the valve is operated. The valve always remains at the same height.

The definition variables are as follows:

H1: Distance from the valve's centre to the base of the stand.

d1: Separation from the wall to the end of the connecting flange.

Characteristics:

- Standard actuators: Handwheel and "Square Nut"
- A pipe support-guide is recommended every 1.5m.
- The standard materials are: EPOXY coated carbon steel and stainless steel.

3 - Extension: Extended Support Plates (Fig. 14)

When a short extension is required, it can be achieved by extending the support plates. An intermediate yoke can be fitted to reinforce the support plates' structure.

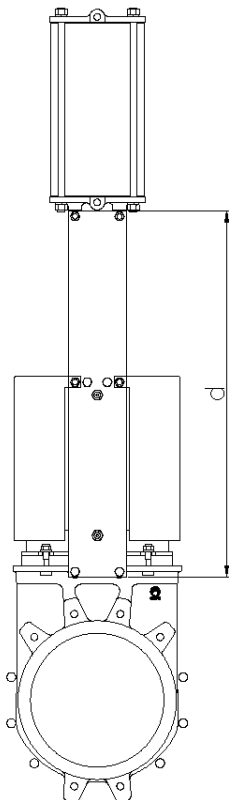

fig. 14

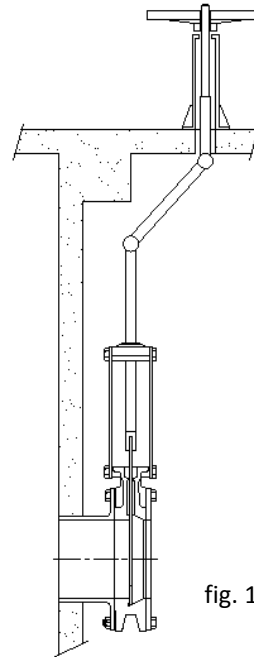

fig. 15

4 - Extension: Universal Joint (Fig. 15)

If the valve and the actuator are not in correct alignment, the problem can be resolved by fitting a universal joint.

KNIFE-GATE VALVES

A SERIES

HANDWHEEL with Rising Stem

- **B = Max. width** of the valve (without actuator)
D = Max. height of the valve (without actuator)
- Options:
 - Locking devices
 - Extensions: stand, pipe, plates...
 - ND higher than those give in the table
- Actuator including:
 - Handwheel
 - Stem
 - Nut
 - Stem protection hood
- Available: ND50 to ND 1200, other ND on request.
- From DN600 the actuator is with gears.

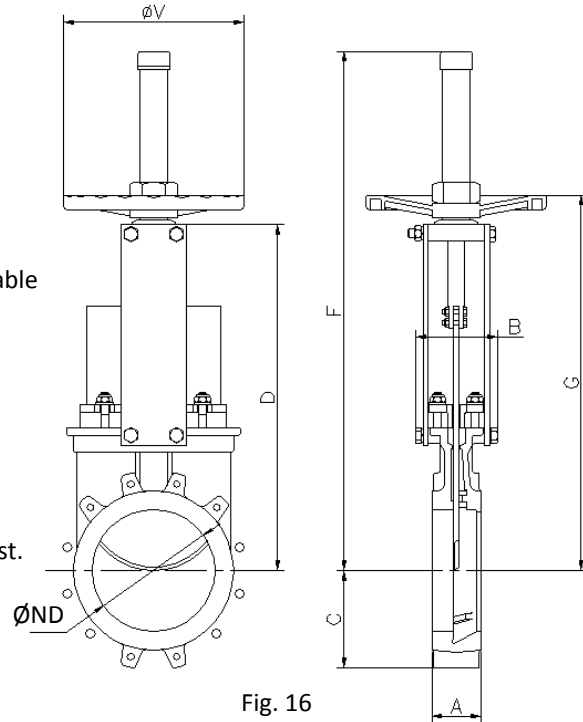

Fig. 16

ND	ΔP (Kg/cm ²)	DRAW (Nw)	TORQ. (Nm)	A	B	C	D	F	G	ϕV	Weight (kg.)
50	10	815	1.86	40	91	61	241	410	280	225	7
65	10	1375	3.14	40	91	68	268	437	308	225	8
80	10	2083	4.76	50	91	91	294	463	333	225	9
100	10	3252	7.43	50	91	104	334	503	373	225	11
125	10	5080	11.6	50	101	118	367	586	407	225	13
150	10	5134	11.7	60	101	130	419	638	458	225	17
200	8	9138	26.1	60	118	159	525	816	578	325	28
250	6	10227	29.2	70	118	196	626	1017	679	325	40
300	6	14748	42.1	70	118	230	726	1117	779	380	56
350	5	16064	62.3	96	290	254	797	1337	906	450	94
400	5	21042	81.6	100	290	287	903	1443	1012	450	116
450	3	20043	77.7	106	290	304	989	1629	1098	450	162
500	3	24883	96.5	110	290	340	1101	1741	1210	450	191
600	3	36081	139.9	110	290	398	1307	2047	1416	450	264
700	2	39945	180.1	110	320	453	1506	--	--	--	441
800	2	43493	237.8	110	320	503	1720	--	--	--	568
900	2	55024	300.9	110	320	583	1953	--	--	--	736
1000	2	68580	374.9	110	320	613	2137	--	--	--	921
1200	2	99025	642.5	150	340	728	2616	--	--	--	1350

Table 4

KNIFE-GATE VALVES

A SERIES

HANDWHEEL with Non-Rising Stem

- Suitable when no size limitations exist.
- **B = Max. width** of the valve (without actuator)
D = Max. height of the valve (without actuator)
- Options:
 - Square nut
 - Locking devices
 - Extensions: stand, pipe, plates...
 - DN higher than those give in the table
- Actuator including:
 - Handwheel
 - Stem
 - Guide bearings on the yoke.
 - Nut
- Available: ND50 to ND2000, other ND on request.
- From DN600 the actuator is with gears.

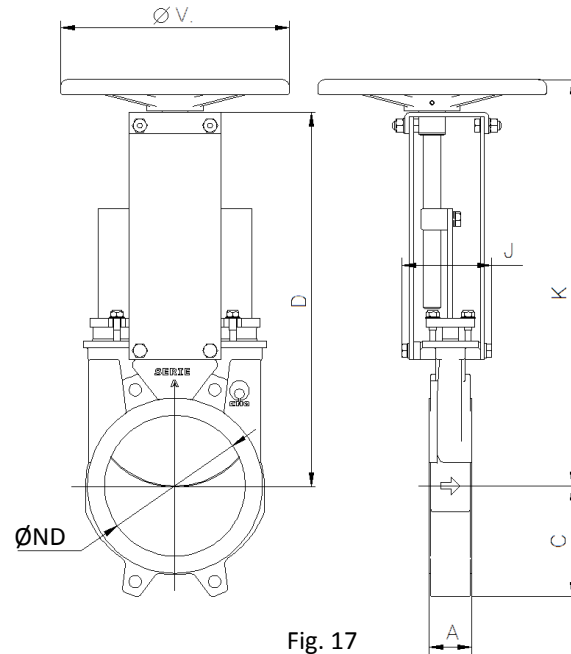

Fig. 17

ND	ΔP (Kg/cm ²)	DRAW (Nw)	TORQUE (Nm)	A	C	D	J	K	ϕV	Weight (kg.)
50	10	815	1.86	40	61	241	101	280	225	7
65	10	1375	3.14	40	68	268	101	308	225	8
80	10	2083	4.76	50	91	294	101	333	225	9
100	10	3252	7.43	50	104	334	101	373	225	11
125	10	5080	11.6	50	118	367	111	407	225	13
150	10	5134	11.7	60	130	419	111	458	225	17
200	8	9138	26.1	60	159	525	128	578	325	29
250	6	10227	29.2	70	196	626	128	679	325	40
300	6	14748	42.1	70	230	726	128	779	380	53
350	5	16064	62.3	96	254	797	305	906	450	93
400	5	21042	81.6	100	287	903	305	1012	450	126
450	3	20043	77.7	106	304	989	305	1098	450	160
500	3	24883	96.5	110	340	1101	305	1210	450	193
600	3	36081	139.9	110	398	1307	305	1416	450	264
700	2	39945	180.1	110	453	1506	335	--	--	435
800	2	43493	237.8	110	503	1720	335	--	--	580
900	2	55024	300.9	110	583	1953	335	--	--	740
1000	2	68580	374.9	110	613	2137	335	--	--	925
1200	2	99025	642.5	150	728	2616	355	--	--	1350

Table 5

KNIFE-GATE VALVES

A SERIES

CHAINWHEEL

- Widely used in raised installations with difficult access, the handwheel is fitted in vertical position.
- **B = Max. width** of the valve (without actuator)
D = Max. height of the valve (without actuator)
- Options:
 - Locking devices
 - Extensions: stand, pipe, plates...
 - Non-rising stem
 - DN higher than those give in the table
- Including:
 - Handwheel
 - Stem
 - Nut
 - Hood
- Available: ND50 to ND1200, other ND on request.
- From DN600 the actuator is with gears, see * in table.

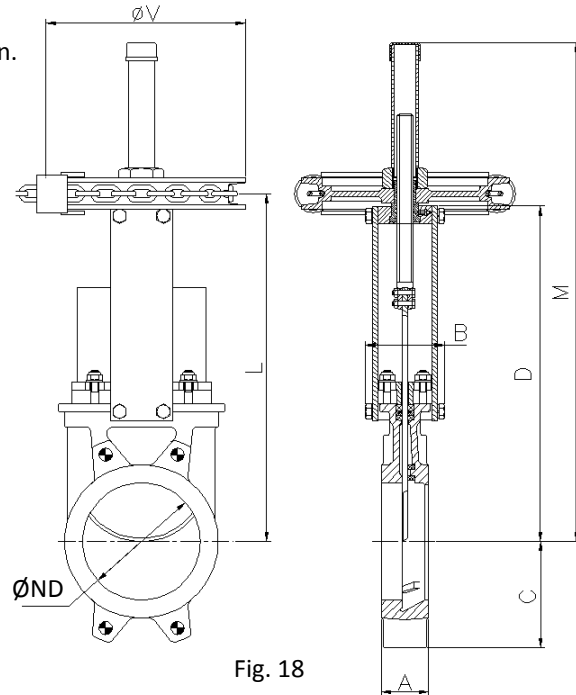

Fig. 18

ND	ΔP (Kg/cm ²)	DRAW (Nw)	TORQ. (Nm)	A	B	C	D	L	M	ϕV	Weight (kg.)
50	10	815	1.86	40	91	61	241	280	410	225	7
65	10	1375	3.14	40	91	68	268	308	437	225	8
80	10	2083	4.76	50	91	91	294	333	463	225	9
100	10	3252	7.43	50	91	104	334	373	503	225	11
125	10	5080	11.6	50	101	118	367	407	586	225	13
150	10	5134	11.7	60	101	130	419	458	638	225	17
200	8	9138	26.1	60	118	159	525	578	816	300	29
250	6	10227	29.2	70	118	196	626	679	1017	300	40
300	6	14748	42.1	70	118	230	726	779	1117	300	53
350	5	16064	62.3	96	290	254	797	906	1337	402	93
400	5	21042	81.6	100	290	287	903	1012	1443	402	126
450	3	20043	77.7	106	290	304	989	1098	1629	402	160
500	3	24883	96.5	110	290	340	1101	1210	1741	402	193
600	3	36081	139.9	110	290	398	1307	1416	2047	402	264
700	2	39945	180.1	110	320	453	1506	1658	2406	402*	435
800	2	43493	237.8	110	320	503	1720	1905	2790	402*	580
900	2	55024	300.9	110	320	583	1953	2115	3130	402*	740
1000	2	68580	374.9	110	320	613	2137	2310	3440	402*	925
1200	2	99025	642.5	150	340	728	2616	2815	4050	402*	1350

Table 6

C.M.O.

KNIFE-GATE VALVES

A SERIES

LEVER

- It is a fast actuator
- **B = Max. width** of the valve (without actuator)
D = Max. height of the valve (without actuator)
- The actuator includes:
 - Lever
 - Rod
 - Guide bearing
 - External limiting switches to maintain the position
- Available: ND50 to ND300, other ND on request.

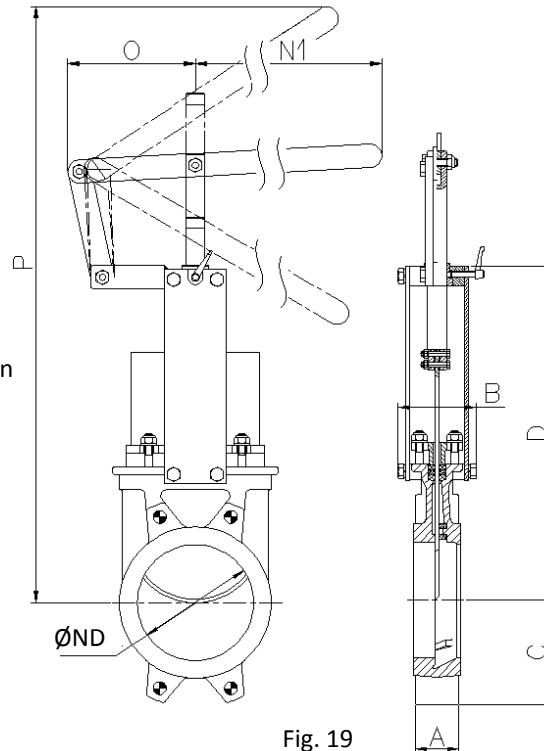

Fig. 19

ND	ΔP (Kg/cm ²)	DRAW (Nw)	A	B	C	D	N	O	P	Weight (kg.)
50	10	815	40	91	61	241	325	155	504	8
65	10	1375	40	91	68	268	325	155	526	9
80	10	2083	50	91	91	294	325	155	549	10
100	10	3252	50	91	104	334	325	155	605	11
125	10	5080	50	101	118	367	425	155	902	14
150	10	5134	60	101	130	419	425	155	956	16
200	8	9138	60	118	159	525	620	290	1027	32
250	6	10227	70	118	196	626	620	290	1416	54
300	6	14748	70	118	230	726	620	290	1525	57

Table 7

KNIFE-GATE VALVES

A SERIES

GEAR BOX

- It is recommendable for DN greater than 600.
- **B = Max. width** of the valve (without actuator)
D = Max. height of the valve (without actuator)
- Options:
 - Chainwheel
 - Locking devices
 - Extensions: stand, pipe, plates...
 - Non-rising stem
- Actuator including:
 - Stem
 - Yoke
 - Cone-shaped gear box
 - Handwheel
- Standard ratio = 4 to 1.
- Available: ND 50 to ND 2000, other ND on request.

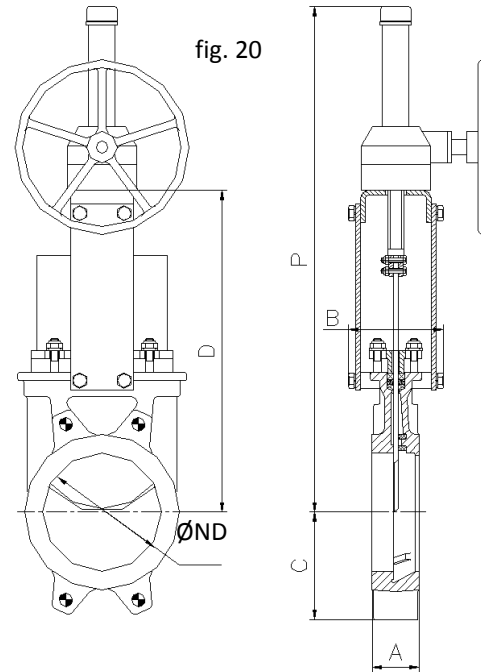

DN	ΔP (Kg/cm ²)	DRAW (Nw)	TORQ. (Nm)	A	B	C	D	P	Weight (kg.)
50	10	815	1.86	40	91	61	241	540	17
65	10	1375	3.14	40	91	68	268	566	18
80	10	2083	4.76	50	91	91	294	592	19
100	10	3252	7.43	50	91	104	334	632	20
125	10	5080	11.6	50	101	118	367	665	24
150	10	5134	11.7	60	101	130	419	717	26
200	8	9138	26.1	60	118	159	525	942	50
250	6	10227	29.2	70	118	196	626	1043	63
300	6	14748	42.1	70	118	230	726	1194	77
350	5	16064	62.3	96	290	254	797	1335	106
400	5	21042	81.6	100	290	287	903	1441	134
450	3	20043	77.7	106	290	304	989	1677	173
500	3	24883	96.5	110	290	340	1101	1789	216
600	3	36081	139.9	110	290	398	1307	2045	284
700	2	39945	180.1	110	320	453	1506	2401	430
800	2	43493	237.8	110	320	503	1720	2715	615
900	2	55024	300.9	110	320	583	1953	3043	768
1000	2	68580	374.9	110	320	613	2137	3351	972
1100	2	83196	539.8	150	340	670	2375	3675	1142
1200	2	99026	642.5	150	340	728	2616	4042	1298
1300	2	117653	763.3	150	390	787	2882	4382	1400
1400	2	136884	888.1	150	390	837	3250	4852	N.D.
1500	2	158591	1190.6	170	426	890	3517	5217	N.D.
1600	2	180653	1518.6	170	426	957	3775	5575	N.D.
1700	2	204052	1715.2	190	440	1010	4008	5908	N.D.
1800	2	230715	1939.4	190	440	1057	4242	6242	N.D.
1900	2	258472	2172.6	210	480	1110	4390	6490	N.D.
2000	2	289155	2760.9	210	480	1162	4540	6740	N.D.

N.D.: Weight not given

Table 8

C.M.O.

KNIFE-GATE VALVES

A SERIES

DOUBLE-ACTING PNEUMATIC CYLINDER

- CMO double-acting pneumatic actuators are designed to work at a pressure between 6 and 10 kg/cm².
- 10 Kg/cm² is the maximum admissible air pressure. For air pressures below 6 Kg/cm² please consult manufacturer.
- For ND50 to ND200 valves, the cylinder's jacket and covers are made of aluminium, the rod of AISI304, the piston of rubber-coated steel and the O-ring seals are made of nitrile.
- For valves larger than ND200 the covers are made of nodular cast iron or carbon steel.
- On request, we can also supply the actuator made entirely of stainless steel, especially for installation in corrosive atmospheres.
- **B = Max. width** of the valve (without actuator)
D = Max. height of the valve (without actuator)
- Available: ND50 to ND1200, other ND on request.

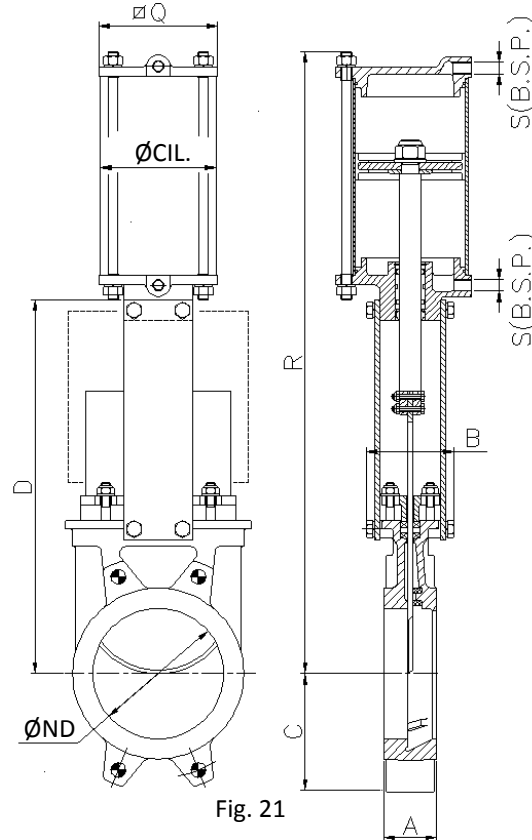

Fig. 21

ND	ΔP (Kg/cm ²)	DRAW (Nw)	A	B	C	D	\varnothing CIL.	\varnothing ROD	$\varnothing Q$	S (B.S.P.)	R	Weight (kg.)
50	10	815	40	91	61	241	80	20	96	1/4"	416	7
65	10	1375	40	91	68	268	80	20	96	1/4"	456	8
80	10	2083	50	91	91	294	80	20	96	1/4"	498	9
100	10	3252	50	91	104	334	100	20	115	1/4"	562	12
125	10	5080	50	101	118	367	125	25	138	1/4"	636	18
150	10	5134	60	101	130	419	125	25	138	1/4"	717	22
200	8	9138	60	118	159	525	160	30	175	1/4"	874	37
250	6	10227	70	118	196	626	200	30	218	3/8"	1036	58
300	6	14748	70	118	230	726	200	30	218	3/8"	1182	72
350	5	16064	96	290	254	797	250	40	270	3/8"	1381	130
400	5	21042	100	290	287	903	250	40	270	3/8"	1530	155
450	3	20043	106	290	304	989	300	45	382	1/2"	1676	225
500	3	24883	110	290	340	1101	300	45	382	1/2"	1839	257
600	3	36081	110	290	398	1307	300	45	382	1/2"	2146	340
700	2	39945	110	320	453	1506	350	45	426	1/2"	2481	556
800	2	43493	110	320	503	1720	350	45	426	1/2"	2798	679
900	2	55024	110	320	583	1953	400	50	508	1/2"	3167	840
1000	*	*	110	320	613	2137	400	50	508	1/2"	3451	1053
1100	*	*	150	340	670	2375	400	50	508	1/2"	3792	1210
1200	*	*	150	340	728	2616	400	50	508	1/2"	4135	1366

* → Consult

Table 9

C.M.O.

KNIFE-GATE VALVES

A SERIES

SINGLE-ACTING PNEUMATIC CYLINDER

- CMO single-acting pneumatic actuators are designed to work at a pressure between 6 and 10 kg/cm².
- 10 Kg/cm² is the maximum admissible air pressure. For air pressures below 6 Kg/cm² please consult manufacturer.
- Available for opening or closing in case of failure (spring opening or closing).
- The jacket is made of aluminium, the covers of nodular cast iron or carbon steel, the rod of AISI304, the piston of rubber-coated steel, the O-ring seals of nitrile and the spring is made of steel.
- The actuator design is spring activated for valves with diameters up to ND300. For larger diameters the actuator contains a double-acting cylinder and an air tank which stores the volume of air necessary to perform the last movement in the event of a fault.
- **B = Max. width** of the valve (without actuator)
D = Max. height of the valve (without actuator)
- Available: ND50 to ND1200, other ND on request.

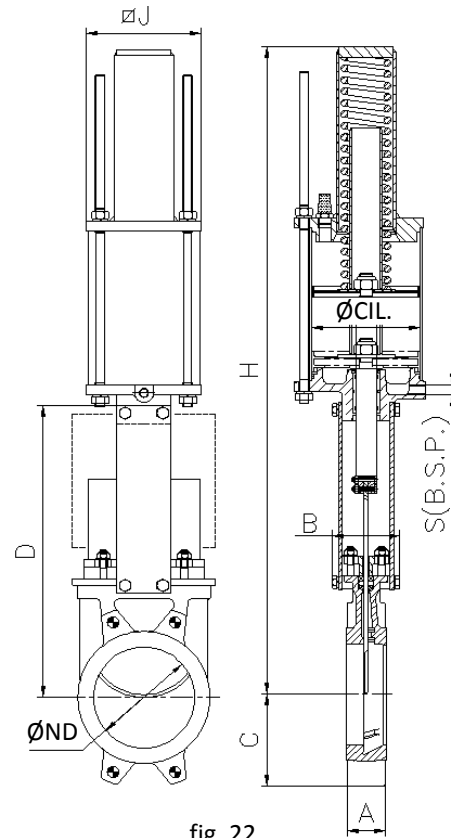

fig. 22

Note: Please see the "CMO Pneumatic Actuators" catalogue if you require further information.

ND	ΔP (Kg/cm ²)	DRAW (Nw)	A	B	C	D	Ø CIL.	ØJ	S (B.S.P.)	Ø ROD	H	Weight (kg.)
50	10	815	40	91	61	241	125	135	1/4"	25	781	19
65	10	1375	40	91	68	268	125	135	1/4"	25	806	22
80	10	2083	50	91	91	294	125	135	1/4"	25	833	23
100	10	3252	50	91	104	334	125	135	1/4"	25	873	24
125	10	5080	50	101	118	367	160	170	1/4"	30	909	35
150	10	7316	60	101	130	419	160	170	1/4"	30	960	36
200	8	13017	60	118	159	525	200	215	3/8"	30	1355	66
250	6	20352	70	118	196	626	250	270	3/8"	40	1844	130
300	6	29342	70	118	230	726	250	270	3/8"	40	2005	143

Table 10

C.M.O.

KNIFE-GATE VALVES

A SERIES

ELECTRIC ACTUATOR

- This actuator is automatic and includes the following parts:
 - Electric motor
 - Stem
 - Yoke
- The electric motor includes:
 - Emergency manual handwheel
 - Limit switches
 - Torque switches
- Options:
 - Different types and brands
 - Non-rising stem
- ISO 5210 / DIN 3338 Flanges
- Available: ND 50 to ND 2000, other ND on request.
- From DN500 the motor is assisted with a gear box.

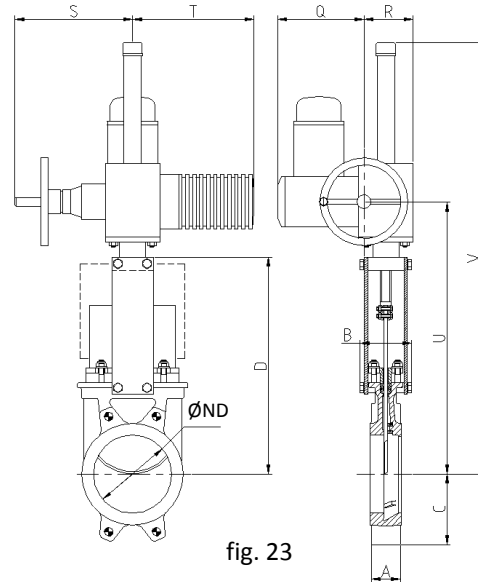

fig. 23

ND	ΔP (Kg/cm ²)	DRAW (Nw)	TORQ. (Nm)	A	B	C	D	Q	R	S	T	U	V	Weight (kg.)
50	10	815	1.86	40	91	61	241	197	102	234	265	347	587	24
65	10	1375	3.14	40	91	68	268	197	102	234	265	374	614	25
80	10	2083	4.76	50	91	91	294	197	102	234	265	400	640	26
100	10	3252	7.43	50	91	104	334	197	102	234	265	440	680	27
125	10	5080	11.6	50	101	118	367	197	102	234	265	473	713	30
150	10	5134	11.7	60	101	130	419	197	102	234	265	525	765	32
200	8	9138	26.1	60	118	159	525	197	102	234	265	640	880	42
250	6	10227	29.2	70	118	196	626	197	102	234	265	741	981	55
300	6	14748	42.1	70	118	230	726	197	102	234	265	841	1141	72
350	5	16064	62.3	96	290	254	797	197	115	256	282	944	1347	99
400	5	21042	81.6	100	290	287	903	197	115	256	282	1050	1550	136
450	3	20043	77.7	106	290	304	989	222	153	325	385	1147	1847	166
500	3	24883	96.5	110	290	340	1101	222	153	325	385	1259	1959	245
600	3	36081	139.9	110	290	398	1307	222	153	325	385	1465	2165	362
700	2	39945	180.1	110	320	453	1506	222	153	325	385	1651	2451	432
800	2	43493	237.8	110	320	503	1720	222	153	332	385	1865	2665	630
900	2	55024	300.9	110	320	583	1953	222	153	332	385	2098	2998	764
1000	2	68580	374.9	110	320	613	2137	222	153	332	385	2288	3178	998
1100	2	83196	539.8	150	340	670	2375	227	195	355	510	2575	3675	1194
1200	2	99026	642.5	150	340	728	2616	227	195	355	510	2866	4042	1350
1300	2	117653	763.3	150	390	787	2882	227	195	355	510	3082	4382	1452
1400	2	136884	888.1	150	390	837	3250	222	153	332	385	3395	4852	N.D.
1500	2	158591	1190.6	170	426	890	3517	222	153	332	385	3662	5217	N.D.
1600	2	180653	1518.6	170	426	957	3775	227	195	355	510	3975	5575	N.D.
1700	2	204052	1715.2	190	440	1010	4008	227	195	355	510	1210	5908	N.D.
1800	2	230715	1939.4	190	440	1057	4242	227	195	355	510	1257	6242	N.D.
1900	2	258472	2172.6	210	480	1110	4390	227	195	355	510	4590	6490	N.D.
2000	2	289155	2760.9	210	480	1162	4540	227	195	355	510	4740	6740	N.D.

N.D.: Weight not given

Table 11

C.M.O.

KNIFE-GATE VALVES

A SERIES

HYDRAULIC ACTUATOR (Oil pressure: 135 Kg/cm²)

- **B = Max. width** of the valve (without actuator)
- **D = Max. height** of the valve (without actuator)
- The hydraulic actuator includes:
 - Hydraulic cylinder
 - Puente
- Available: ND 50 a ND 2000
- Different types and brands available according to customer's requirements.

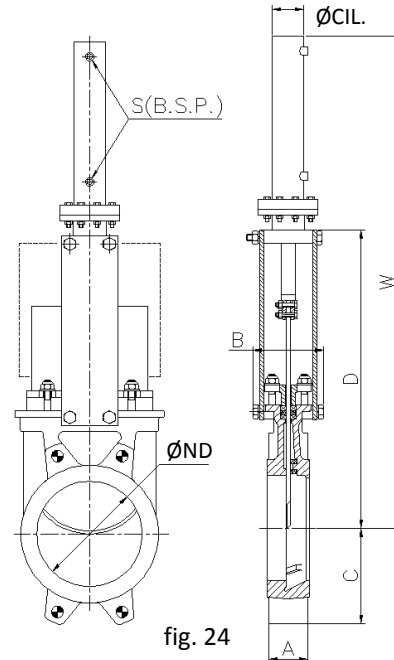

fig. 24

ND	ΔP Kg/cm ²	DRAW (Nw)	A	B	C	D	W	Ø CYL.	S (B.S.P.)	Oil Cap. (dm ³)	Ø ROD	Wei ght (kg.)
50	10	815	40	91	61	241	457	25	3/8"	0.03	18	7
65	10	1375	40	91	68	268	500	25	3/8"	0.03	18	8
80	10	2083	50	91	91	294	560	25	3/8"	0.04	18	9
100	10	3252	50	91	104	334	620	32	3/8"	0.09	22	12
125	10	5080	50	101	118	367	683	32	3/8"	0.11	22	15
150	10	5134	60	101	130	419	755	40	3/8"	0.20	28	20
200	8	9138	60	118	159	525	926	50	3/8"	0.27	28	31
250	6	10227	70	118	196	626	1077	50	3/8"	0.33	28	44
300	6	14748	70	118	230	726	1246	50	3/8"	0.97	28	62
350	5	16064	96	290	254	797	1376	50	3/8"	1.13	28	100
400	5	21042	100	290	287	903	1532	63	3/8"	1.29	36	138
450	3	20043	106	290	304	989	1707	63	3/8"	2.31	36	161
500	3	24883	110	290	340	1101	1869	63	3/8"	2.58	36	223
600	3	36081	110	290	398	1307	2176	80	3/8"	3.09	45	325
700	2	39945	110	320	453	1506	2525	80	1/2"	5.66	45	481
800	2	43493	110	320	503	1720	2839	100	1/2"	6.46	56	678
900	2	55024	110	320	583	1953	3172	100	1/2"	7.25	56	861
1000	2	68580	110	320	613	2137	3496	125	1/2"	8.05	70	1103
1100	2	83196	150	340	670	2375	3760	125	1/2"	8.84	70	1266
1200	2	99026	150	340	728	2616	4174	125	1/2"	9.62	70	1430
1300	2	117653	150	390	787	2882	4451	160	1/2"	10.45	70	1647
1400	2	136884	150	390	837	3250	4939	160	1/2"	11.39	70	N.D.
1500	2	158591	170	426	890	3517	5286	160	1/2"	12.02	70	N.D.
1600	2	180653	170	426	957	3775	5658	160	1/2"	20.00	70	N.D.
1700	2	204052	190	440	1010	4008	5991	200	1/2"	21.23	90	N.D.
1800	2	230715	190	440	1057	4242	6325	200	1/2"	22.46	90	N.D.
1900	2	258472	210	480	1110	4390	6578	200	1/2"	23.75	90	N.D.
2000	2	289155	210	480	1162	4540	6828	200	1/2"	24.97	90	N.D.

N.D.: Weight not given

Table 12

C.M.O.

KNIFE-GATE VALVES

A SERIES

INFORMATION ON FLANGE DIMENSIONS

EN 1092-2 PN10

ND	ΔP (Kg/cm ²)	•	O	Metric	Prof	ϕK
50	10	4	-	M 16	8	125
65	10	4	-	M 16	8	145
80	10	4	4	M 16	9	160
100	10	4	4	M 16	9	180
125	10	4	4	M 16	9	210
150	10	4	4	M 20	10	240
200	8	4	4	M 20	10	295
250	6	6	6	M 20	12	350
300	6	6	6	M 20	12	400
350	5	10	6	M 20	21	460
400	5	10	6	M 24	21	515
450	3	14	6	M 24	22	565
500	3	14	6	M 24	22	620
600	3	14	6	M 27	22	725
700	2	16	8	M 27	22	840
800	2	16	8	M 30	22	950
900	2	20	8	M 30	20	1050
1000	2	20	8	M 33	20	1160
1100	2	20	12	M 33	20	1270
1200	2	20	12	M 36	22	1380
1300	2	20	12	M 36	26	1490
1400	2	24	12	M 39	26	1590
1500	2	24	12	M 39	35	1700
1600	2	28	12	M 45	40	1820
1700	2	30	14	M 45	40	1920
1800	2	30	14	M 45	40	2020
1900	2	32	16	M 45	45	2120
2000	2	32	16	M 45	45	2230

Table 13

ANSI B16, class 150

ND	ΔP (Kg/cm ²)	•	O	R UNC	Prof.	ϕK
2"	10	4	-	5/8"	8	120,6
2 1/2"	10	4	-	5/8"	8	139,7
3"	10	4	-	5/8"	9	152,4
4"	10	4	4	5/8"	9	190,5
5"	10	4	4	3/4"	9	215,9
6"	10	4	4	3/4"	10	241,3
8"	8	4	4	3/4"	10	298,4
10"	6	6	6	7/8"	12	361,9
12"	6	6	6	7/8"	12	431,8
14"	5	8	4	1"	21	476,2
16"	5	10	6	1"	21	539,7
18"	3	10	6	1 1/8"	22	577,8
20"	3	14	6	1 1/8"	22	635
24"	3	14	6	1 1/8"	22	749,3
28"	2	20	8	1 1/8"	22	863,6
30"	2	20	8	1 1/8"	22	914,4
32"	2	18	10	1 1/2"	22	977,9
36"	2	20	12	1 1/2"	20	1085,9
40"	2	24	12	1 1/2"	20	1200,2

Table 14

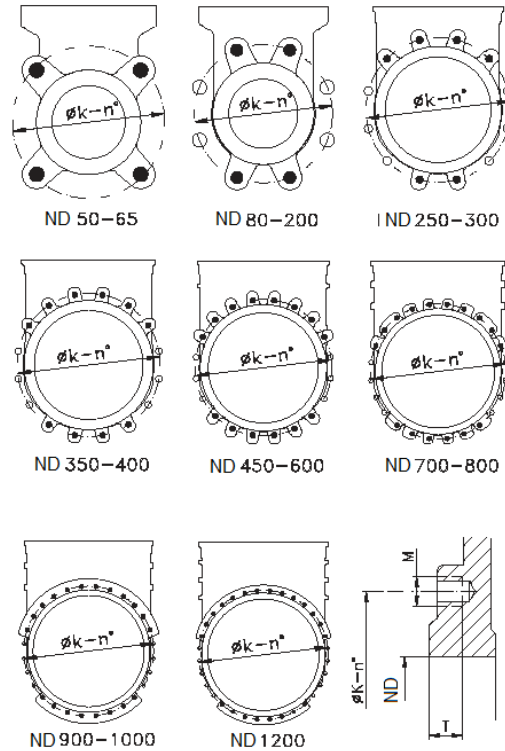
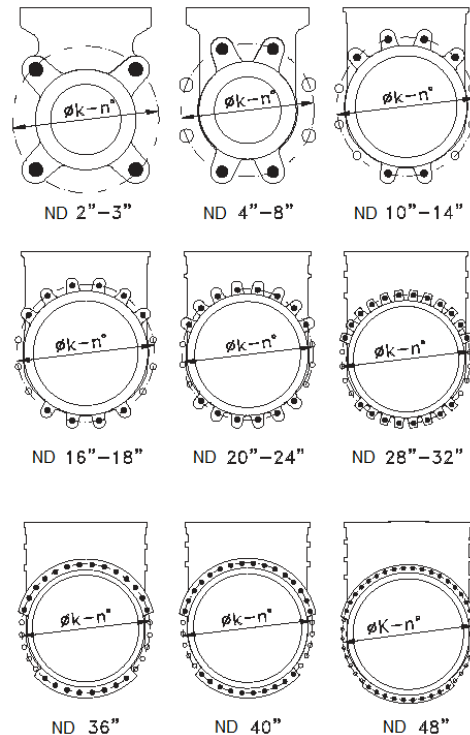

fig. 25

• BLIND TAPPED HOLES
○ THROUGH HOLE



C.M.O.